



# HIGH PERFORMANCE MAX SERIES PUMP WITH OASIS™ WETSEAL FMC-750F-HYD



## We look for inspiration everywhere!

Introducing the new 750 Max Series with Oasis™ WetSeal Technology. The Oasis™ Innovation isolates seals from the pump flow so you'll never have to worry about run dry or abrasive wear failure. Perfect for today's high-pressure applications, our innovative design generates higher pressure at lower RPMs ensuring maximum canopy penetration and efficiency.



## **750** **MAX SERIES**

### Advantages:

- Oasis™ WetSeal Technology
- E-Coat Protection for added corrosion resistance
- 4000 PSI High efficiency hydraulic motors
- Powerful splined motor to pump shaft connection
- Oversized bearings
- Pressure balanced impeller

### Port Specifications:

- Suction – 300 Standard Series Flange
- Discharge – 220 Full Port Series Flange

### Available 750 models:

- FMC-750F-HYD-M22 - 18 GPM hydraulic motor
- FMC-750F-HYD-M25 - 20 GPM hydraulic motor

[www.AcePumps.com](http://www.AcePumps.com)

901-948-8514 • 1650 Channel Avenue  
Memphis, TN 38113

To determine the approximate horsepower requirements for your centrifugal pump  
at a given flow and pressure:

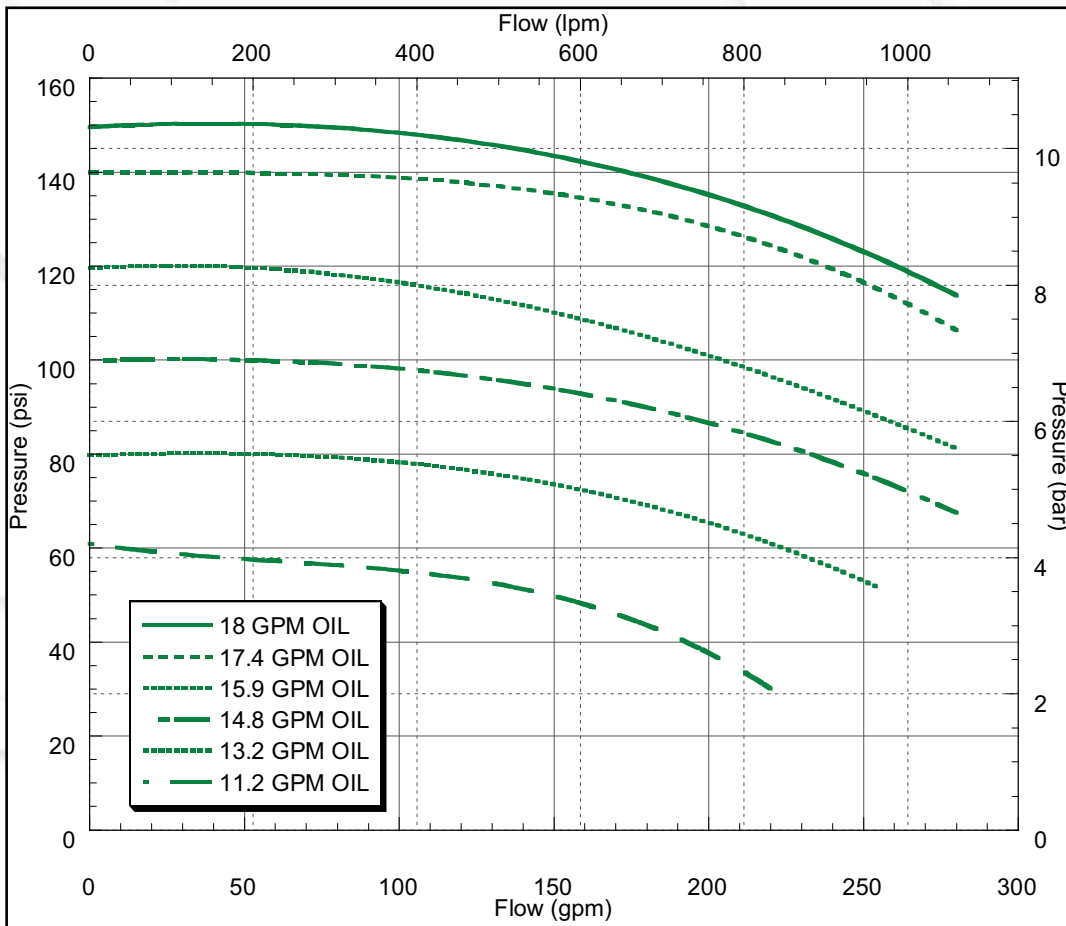
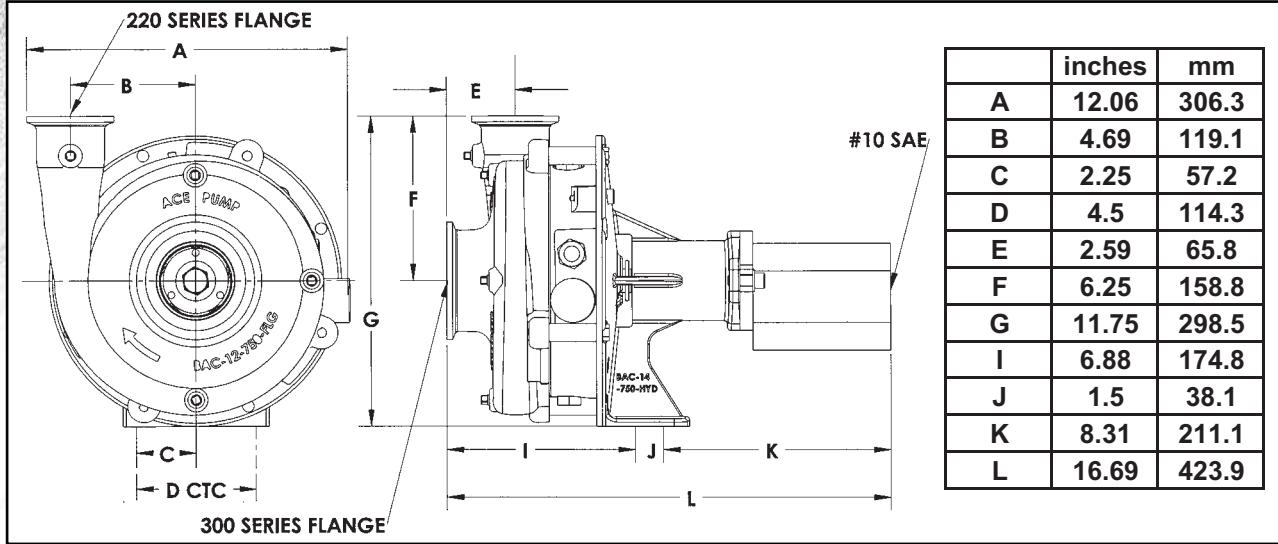

Dimension and performance shown using M22 motor.

www.AcePumps.com  
 901-948-8514 • 1650 Channel Avenue  
 Memphis, TN 38113

at a given flow and pressure  
 FMC-750F-HYD-SLS